

SPECIFICATIONS

Exterior Dimensions: 23¹⁵/₁₆" L x 24¹⁹/₃₂" D x 34" H
 Voltage: 115/60/1
 Amps: 2.3
 Power Cord Length: 8'
 Crated Weight: 240 lbs.
 Shelving: 6 glide-out wine racks - 48 bottles
 1 floor wine cradle - 5 bottles
 Total Capacity: 5.7 ft³
 Lighting: Amber LED
 Temperature: Set to 55°F with a 33°F-65°F range



Specifications subject to change with out notice.

EXCEPTIONAL FEATURES

- > **FREE STANDING OR BUILT-IN FOR ANY SETTING**
Allows for flexibility depending upon the desired application
- > **300 SERIES STAINLESS STEEL INTERIOR / EXTERIOR**
Provides an elegant look and durability, which will prolong the life of your wine cabinet
- > **OVERSIZED / BALANCED FORCED AIR REFRIGERATION SYSTEM**
Enables rapid product pull down and temperatures within 1 degree
- > **FULL AUTO DEFROST**
Auto defrost is programmed into the refrigeration cycle, so there is no need for manual defrost
- > **2" COMMERCIAL GRADE STAINLESS STEEL INSULATED DOOR FRAME TECHNOLOGY**
Heavy-duty door that will add to insulation and longevity of your cabinet
- > **STAY-OPEN DOOR HINGE FEATURE**
This standard feature allows for easy loading and unloading
- > **ELECTRONIC DOOR MOUNTED, BLUE LED TEMPERATURE DISPLAY WITH LED LIGHT CONTROL**
Allows visibility of temperature, as well as ability to turn interior lighting on or off without opening door. Along with sleek integration into the doorframe, the blue LED display provides an elegant complement to the stainless.
- > **AMBER LED INTERIOR LIGHTING**
LED lighting is a non-UV, non-infrared light source, which will aid in preserving your wines. As a low voltage LED lighting, it is not a significant heat source like other types of lighting. This will ensure consistent temperatures throughout the wine cabinet. This will also provide an attractive display of your collection when entertaining.
- > **UV-TINTED, DOUBLE PANE, LOW-E GLASS DOOR**
Protects wine from UV rays, as well as other harmful lights that can affect your wine
- > **GLIDE-OUT WINE RACK WITH TRUE SIGNATURE HANDLE**
Standard with 6 glide-out racks and 1 floor rack. Each glide-out rack is specifically engineered to accomodate wine with anti-racking, vibration-dampening technology.
- > **ANTI-SWEAT KEY LOCK ON DOOR**
Added security to keep out uninvited guests
- > **2 YEARS PARTS AND LABOR WARRANTY WITH AN ADDITIONAL 3 YEARS ON THE SEALED SYSTEM**
- > **UL RATED FOR OUTDOOR USE**

PLAN VIEW

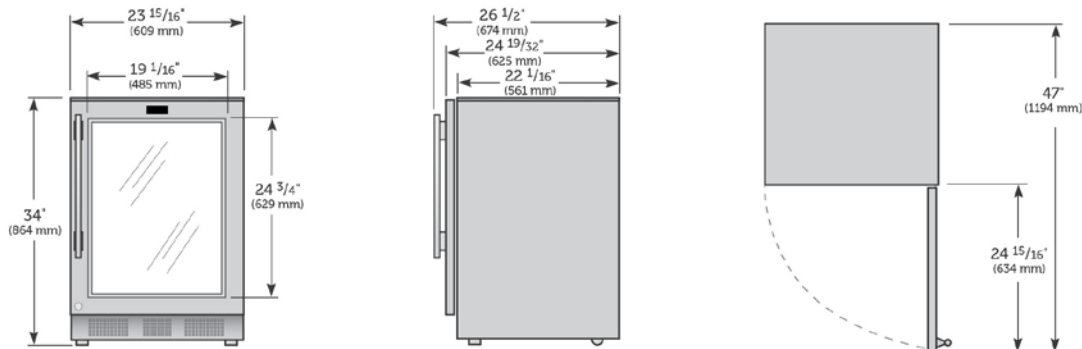

Height Dimensions +/- 1/2"

2001 East Terra Lane, O'Fallon, MO 63366 USA

phone 636.240.2400 toll free 888.616.8783 parts 800.424.8783 fax 636.272.7546

website www.true-residential.com info address info@true-residential.com