



TBC-24 BEVERAGE CENTER

SPECIFICATIONS

Exterior Dimensions: 23¹⁵/₁₆" L x 24¹⁹/₃₂" D x 34" H

Voltage: 115/60/1

Amps: 1.9

Power Cord Length: 8'

Crated Weight: 215 lbs.

Shelving: 2 black, adjustable/removable wire shelves

1 glide-out step wine shelf - 8 wine bottles

Bottom cradle - 5 wine bottles

Total Capacity: 5.6 ft³

Lighting: White LED

Temperature: Set to 35°F with a 33°F-65°F range

Specifications subject to change without notice.



EXCEPTIONAL FEATURES

> FREE STANDING OR BUILT-IN FOR ANY SETTING

Allows for flexibility depending upon the desired application

> 300 SERIES STAINLESS STEEL INTERIOR / EXTERIOR

Provides an elegant look and durability, which will prolong the life of your beverage center

> OVERSIZED / BALANCED FORCED AIR REFRIGERATION SYSTEM

Enables rapid product pull down and temperatures within 1 degree

> FULL AUTO DEFROST

Auto defrost is programmed into the refrigeration cycle, so there is no need for manual defrost

> 2" COMMERCIAL GRADE STAINLESS STEEL INSULATED DOOR FRAME TECHNOLOGY

Heavy-duty door that will add to insulation and longevity of your cabinet

> STAY-OPEN DOOR HINGE FEATURE

This standard feature allows for easy loading and unloading

> ELECTRONIC DOOR MOUNTED, BLUE LED TEMPERATURE DISPLAY WITH LED LIGHT CONTROL

Allows visibility of temperature, as well as ability to turn interior lighting on or off without opening door. A sleek integration into the doorframe provides an elegant complement to the stainless.

> WHITE LED INTERIOR LIGHTING

Low voltage LED lighting is not a significant heat source like other types of lighting and will ensure consistent temperatures throughout the beverage center. This is also an attractive display when entertaining.

> UV-TINTED, DOUBLE PANE, LOW-E GLASS DOOR

Protects wine from UV rays, as well as other harmful lights that can affect your wine

> 2 COMMERCIAL GRADE, BLACK WIRE SHELVES

Adjustable and removable to accommodate a variety of products

> GLIDE-OUT WINE RACK WITH TRUE SIGNATURE HANDLE

Standard with 1 glide-out wine rack, specifically engineered to accommodate wine with anti-racking, vibration-dampening technology

> ANTI-SWEAT KEY LOCK ON DOOR

Added security to keep out unwanted guests

> 2 YEARS PARTS AND LABOR WARRANTY WITH AN ADDITIONAL 3 YEARS ON THE SEALED SYSTEM

> UL RATED FOR OUTDOOR USE

PLAN VIEW

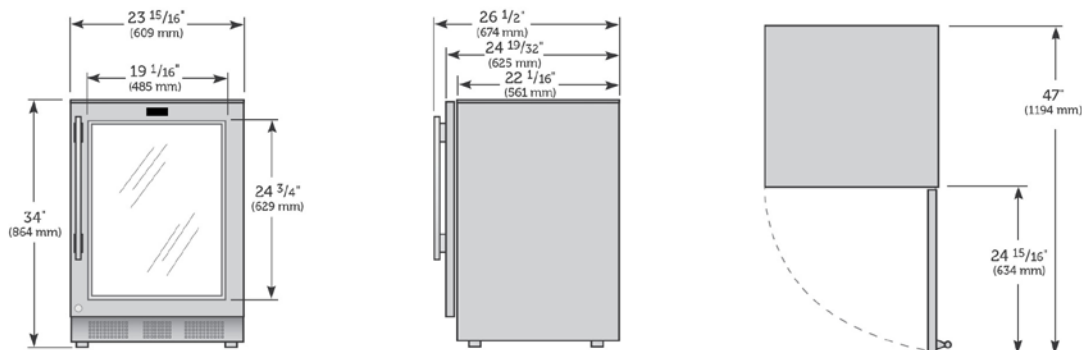

Height Dimensions +/- 1/2"

2001 East Terra Lane, O'Fallon, MO 63366 USA

phone 636.240.2400 toll free 888.616.8783 parts 800.424.8783 fax 636.272.7546

website www.true-residential.com info address info@true-residential.com